

SCALE 2:5

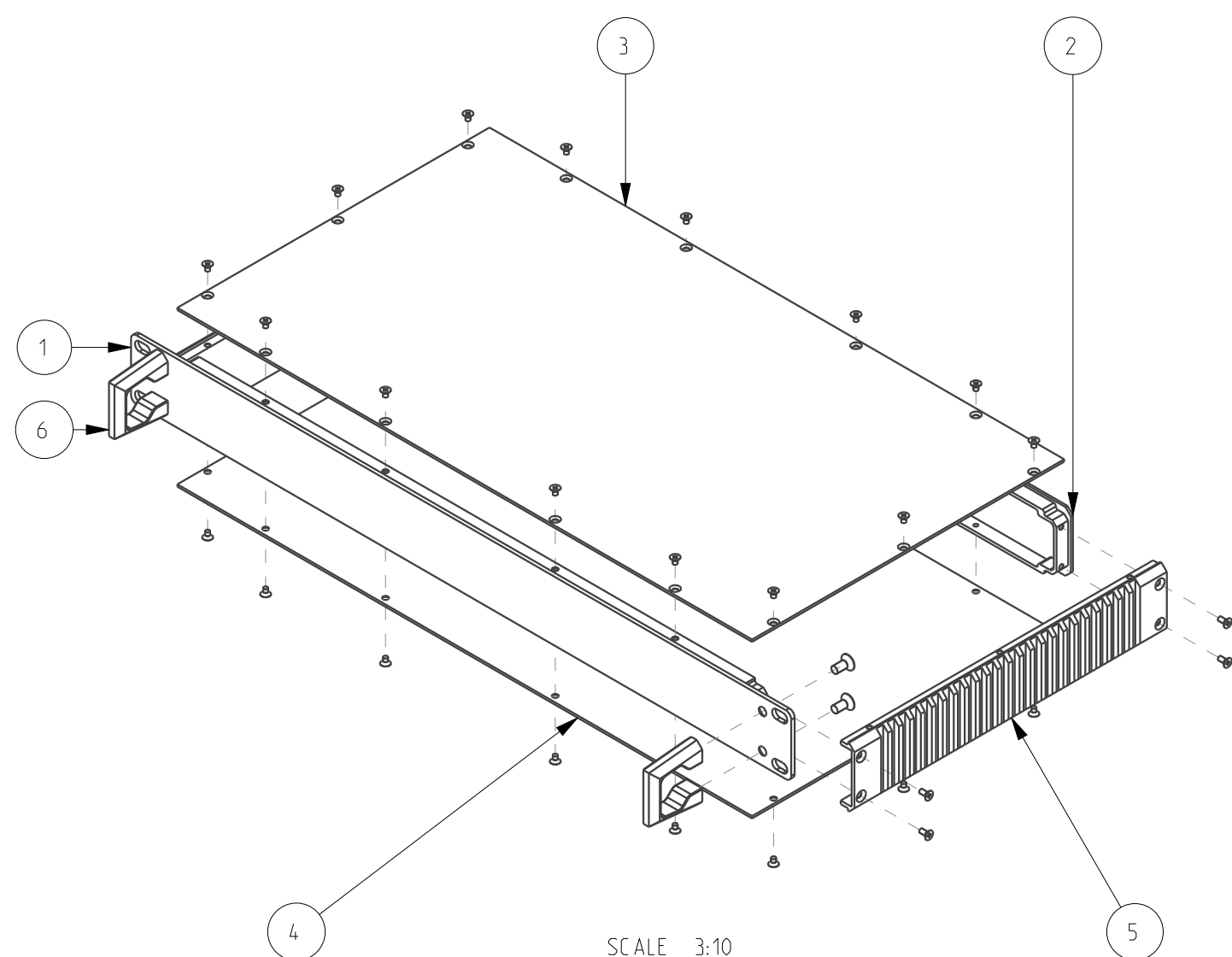

SCALE 3:10

ALL PARTS MADE OF ALUMINUM - SANDBLASTED - ANODIZED BLACK COLOR  
ALL SCREWS INCLUDED - STAINLESS STEEL

ITEM	PART NR.	PART NAME	QTY
1	D1001418	FRONT PANEL	1
2	D1001419	REAR PANEL	1
3	D1001420	TOP PANEL	1
4	D1001421	BOTTOM PANEL	1
5	D1001422	SIDE PANEL	2
6	D1001423	HANDLE 1 UNIT	2

00		ARTICLE CREATION			26/03/20	NIME
INDEX	CHANGE	DESCRIPTION OF MODIFICATION			DATE	NAME
ALL DIMENSIONS ARE IN MM						
General Tolerances ISO2768mK						
Nin.	0.5	30	120	315		
Dim.	30	120	315	1000	PUNCH	BEND MILLING
Tol.	±0.2	±0.3	±0.5	±0.8	±0.15	±0.25 ±0.05
PROJECTION SYMBOL				SCALE	MATERIAL	WEIGHT (Kg)
				1:1		1.5
PART NAME				LAYOUT		
PROJECT				19 INCH RACK MODULE 1U		
<b>METRON TECHNICS</b>				D1001417		
This document is confidential and may not be made use of by or communicated to third parties without permission of METRON TECHNICS						SHEET 1 OF 1
						A2